

Hints & Tips

Locomotive will not run.

If your locomotive does not respond properly to the power controller or runs poorly, please check the following points:

1. Ensure that the power controller is switched on and that all electrical contacts are made correctly and are secure.
2. If a power connecting clip or power track is used, please ensure that the connection to the track is correct.
3. Ensure that all track sections are fitted together correctly and that all 'fishplates' are tightly fitting to all other rails.
4. The locomotive is sitting with all wheels on the track.
5. Check that the power controller is set to operate in one direction or the other and not in the centre 'OFF' position.
6. Ensure that all of the locomotive's wheels and moving parts are free from household dust, fluff and dirt accumulation. Any build up should be gently removed using a pair of fine tweezers.

Track Cleaning.

During normal operating conditions, the track on all model railway layouts accumulates dirt and dust on the running surface of the rails which can be transferred to the locomotive's wheels and electrical pick ups.

Important Safety Notes.

Please read these operation and maintenance instructions prior to operating your locomotive.

This locomotive is not suitable for children under 14 years. It contains small parts which can present a choking hazard and some components have functional sharp points and edges.

Should a build up of dirt be allowed to accumulate, it can cause a locomotive to lose traction and ultimately cause power loss to the locomotive's motor.

It is therefore essential to keep the track and locomotive's wheels absolutely clean to ensure smooth running and reliability by using a track cleaning rubber which can be purchased from any good model shop.

Locomotive body maintenance.

Oxford Rail locomotive bodies are spray painted overall with printed decals and many separately fitted components.

Do not use any solvent type agents to clean the locomotive's body or to remove any marks or greasy stains, as this will damage the locomotive's body decoration.

The locomotive body can be kept clean if needed by gently buffing using a dry, soft, lint free cloth.

Television Suppression.

Oxford Rail locomotives should not interfere with your television or radio when in operation. Should interference occur, it may be due to the close proximity of your layout to receivers or ariels and their 'downlines'. In this case, the layout will need to be moved further away to rectify this issue.

Please handle this product with care.

This locomotive is intended for indoor use only.

This locomotive must not be connected to any other device other than a recognised model railway transformer.



Class 415 Adams Radial Locomotive Operation & Maintenance



The Class 415 later to be reclassified as 0415, Adams Radial was designed by William Adams and introduced in 1882 for operation on the London and South Western Railway (LSWR) with the design being inspired by the early LSWR Class 46. The Class 415 was based on a 4-4-0 wheel configuration but with a trailing bogie which was so fitted to support an enlarged coal bunker that was required for the highly intensive suburban services suitable for the LSWR network. The term 'Radial' refers to the location and positioning of the trailing bogie and how it is located onto the chassis, which in the case of the '415' is in the middle.

The production of the '415' locomotives commenced in 1882 with orders placed with four locomotive works, which by the end of production in 1885 numbered 71. The companies used were Robert Stephenson & Co. who built 28, Dübs & Co. were responsible for 20, Neilson & Co. produced 11 and Beyer, Peacock and Company constructed 12. Under normal circumstances these 71 locomotives would have been built at the LSWR's own works at Nine Elms, however at the time of requirement the Nine Elms locomotive works were working at full capacity and therefore could not accept the order.

Even though all of the 71 were constructed to the same basic design, those locomotives that were built from 1884 onwards had slightly larger side water tanks and deeper fireboxes, the combination of which helped to increase the locomotive's efficiency. All of the Class were built featuring the Adams stove pipe chimney but when Dugald Drummond became Superintendent of the LSWR the Class 415 locomotives were slightly modified with the addition of a lipped chimney. At the same time coal rails were added to the bunker so as to try and increase the locomotive's capacity. None of the locomotives were ever equipped with superheaters.

In service the locomotives found favour with the crews that drove them, however their time as the locomotive of choice for the London suburban services was limited when first the Adams T1 0-4-4 started to replace them from such services. Eventually the introduction of Drummond's M7 linked to the electrification of the routes finally terminated the operation of the '415s' on the London LSWR rails and removing the 'Radials' to rural duties in 1885. However, in 1903 there was a use found for them on the severely curved Lyme Regis branch where such locomotives as the Stroudley Terriers and Adams 02 had proved unsuccessful. Eventually three of the 415 Class had their trailing axles modified and consequently they were found to be most suitable for the demands of that line. Two of the Class were allocated to Exmouth Junction for the Axminster to Lyme Regis route while a third locomotive joined them as late as 1946 having been obtained from the East Kent Railway.

The First World War probably saved the bulk of the class from being scrapped, although by 1921 thirty eight of the Class had been withdrawn. Several of the Adams Radials were used on the Highland Railway while the locomotive that eventually found itself in 1946 working with the remaining two of the Class was in 1917 sold to the Ministry of Munitions and then later worked on Risham Docks close to Sittingbourne. The same locomotive, which was numbered 0488 was eventually purchased by Colonel Stephens for use on the East Kent Railway in 1923 but having remained there and being used sporadically the locomotive was eventually sold and joined the other two remaining Class 0415 locomotives.

With the Grouping of 1923 and the formation of the Southern Railway, only thirty Adams Radials had survived and as already mentioned eventually only three of the Class remained untouched by the Cutter's Torch. These three surviving Adams Radials continued to work on the Lyme Regis branch after Nationalisation as there were no other suitable locomotives available. By 1958 all three of the Class were beginning to show their age and in 1961 all had been withdrawn. After withdrawal numbers 30582, formerly 125 and 30584, formerly 520 were scrapped while locomotive 30583, formerly 488 was obtained by the Bluebell Railway where it can be currently viewed in LSWR livery.



Designed In the UK by Oxford Diecast Ltd, PO Box 62, Swansea SA1 4YA.

Oxford Rail locomotives are precision built using the highest quality components. If treated with reasonable care and with regular maintenance, the locomotive will give many years of

good service. Please ensure that you read the contents of this operation and maintenance sheet to ensure the best possible performance from your locomotive.

Fitting Brake Rodding & Couplings

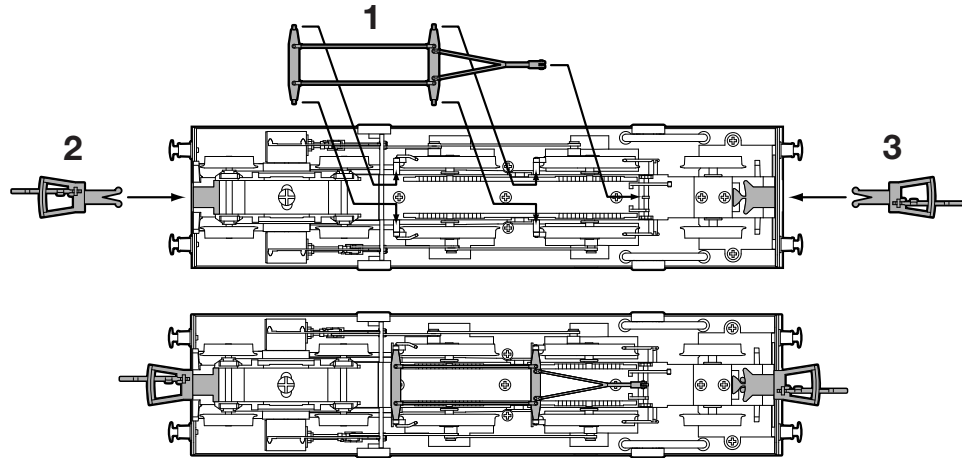

Running In Period & Locomotive Lubrication

Oxford Rail locomotives are carefully engineered scale models and as such require a gentle running in period to be completed prior to normal operating conditions to achieve best results and optimum performance from all working parts.

Do not operate your locomotive on track which has been laid directly on to carpet as the fibres from the carpet or pet hairs can foul the locomotives working parts such as the motor or gears or wrap around axles.

The locomotive will require periodic routine maintenance. After approximately 24 hours of operation the locomotive will require some light lubrication to maintain the locomotive in top operating condition. DO NOT use household lubricants as they can damage the locomotive. Ensure that you only use a recommended light engineering oil such as 3 in 1. Ensure that the oil is only applied to the moving parts as shown on the diagram below using an opened paperclip. DO NOT apply oil to the motor itself.

Any excess oil that may come into contact with the locomotive body should be removed immediately as this could damage the locomotives paint or decals.

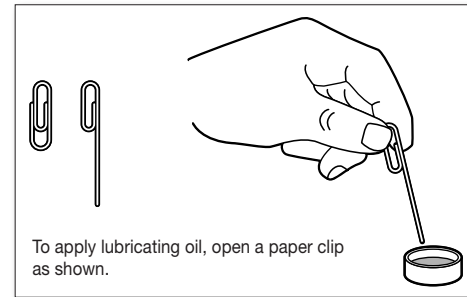

AXLE OIL POINTS

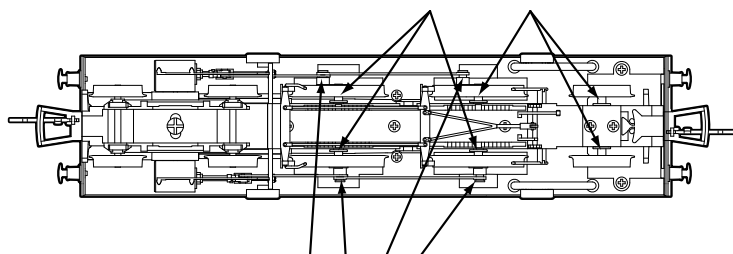

MOTION OIL POINTS

Removal of Locomotive body & DCC Socket location

If your intention is to install a DCC decoder in to your locomotive, it is important to ensure that the locomotive

operates correctly as a DC locomotive prior to DCC installation.

